

Submersible pumps in stainless steel

-  Sewage water
-  Domestic use
-  Civil use
-  Industrial use



PERFORMANCE RANGE

- Flow rate up to **750 l/min** (45 m³/h)
- Head up to **15 m**

APPLICATION LIMITS

- **5 m** maximum immersion depth
- Maximum liquid temperature **+40 °C**
- Passage of suspended solids up to **Ø 50 mm**
- Minimum immersion depth for continuous service: **300 mm**

CONSTRUCTION AND SAFETY STANDARDS

- **10 m** long power cable
- Float switch for single-phase versions

EN 60335-1
IEC 60335-1
CEI 61-150

EN 60034-1
IEC 60034-1
CEI 2-3



CERTIFICATIONS

Company with management system certified DNV
ISO 9001: QUALITY



INSTALLATION AND USE

BC-MF submersible pumps are recommended for draining **dirty and sewage water** in domestic, civil and industrial applications. They come equipped with a **DOUBLE-CHANNEL** impeller and are capable of pumping liquids containing short fibred suspended solids up to Ø 50 mm. They are ideal for pumping sewage, waste water, surface water and water mixed with mud in locations such as blocks of flats and detached house.

These pumps distinguish themselves for their reliability, which can be best appreciated under automatic operating conditions in fixed installations.

PATENTS - TRADE MARKS - MODELS

- Patent n° EP2313658
- Patent Pending n° BO2015A000116

OPTIONS AVAILABLE ON REQUEST

- Single-phase pumps without float switch
- Other voltages or 60 Hz frequency

CHARACTERISTIC CURVES AND PERFORMANCE DATA

50 Hz n= 2900 min⁻¹

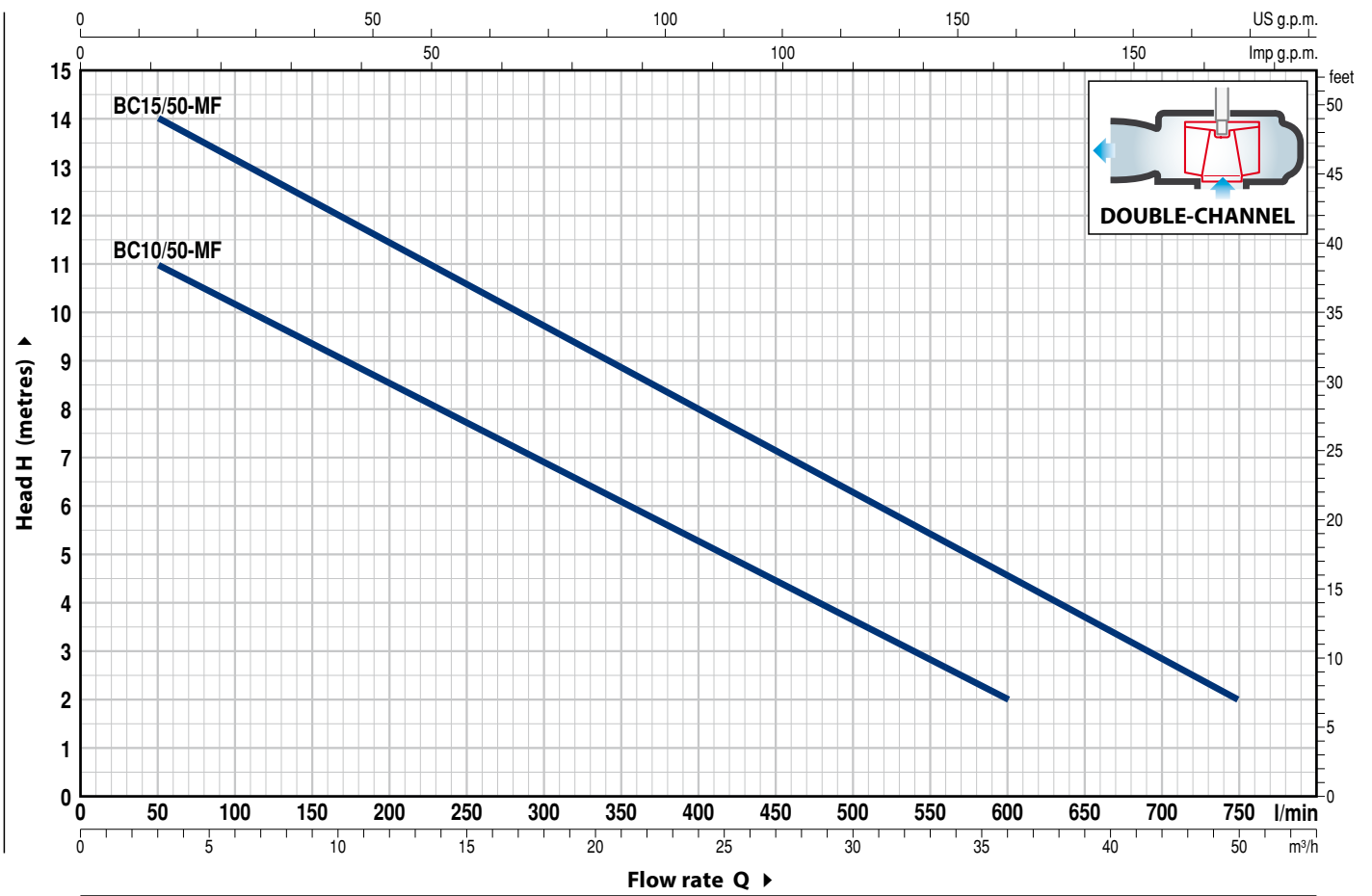

MODEL		POWER (P ₂)		Q	Flow rate													
Single-phase	Three-phase	kW	HP		m ³ /h	0	3	6	12	18	24	30	36	42	45			
				l/min	0	50	100	200	300	400	500	600	700	750				
BCm 10/50-MF	BC 10/50-MF	0.75	1	H metres	12	11	10	8.5	7	5	3.5	2						
BCm 15/50-MF	BC 15/50-MF	1.1	1.5	H metres	15	14	13	11.5	9.7	8	6.3	4.5	3	2				

Q = Flow rate H = Total manometric head

Tolerance of characteristic curves in compliance with EN ISO 9906 Grade 3B.

POS. COMPONENT CONSTRUCTION CHARACTERISTICS

1 PUMP BODY	Precision cast stainless steel AISI 316L with threaded port in compliance with ISO 228/1				
2 BASE	Stainless steel AISI 304				
3 IMPELLER	Precision cast stainless steel AISI 304 DOUBLE-CHANNEL type				
4 MOTOR CASING	Stainless steel AISI 304				
5 MOTOR CASING PLATE	Stainless steel AISI 304				
6 MOTOR SHAFT	Stainless steel AISI 316L				
7 SHAFT WITH DOUBLE MECHANICAL SEAL SEPARATED BY AN OIL CHAMBER					
<i>Seal</i>	<i>Shaft</i>	<i>Position</i>	<i>Stationary ring</i>	<i>Rotational ring</i>	<i>Materials</i>
<i>Model</i>	<i>Diameter</i>				<i>Elastomer</i>
MG1-14D SIC	Ø 14 mm	Motor side	Silicon carbide	Graphite	NBR
		Pump side	Silicon carbide	Silicon carbide	NBR
8 BEARINGS	6203 ZZ / 6203 ZZ				

9 CAPACITOR		
<i>Pump</i>	<i>Capacitance</i>	
<i>Single-phase</i>	<i>(220-230 V or 240 V)</i>	<i>(110 V)</i>
BCm 10/50-MF	20 µF 450 VL	30 µF - 250 VL
BCm 15/50-MF	25 µF 450 VL	-

10 ELECTRIC MOTOR

BCm: single-phase 220-230 V - 50 Hz
with thermal overload protector incorporated into the winding

BC: three-phase 400 V - 50 Hz

- Insulation: class F
- Protection: IP X8

11 POWER CABLE

"H07 RN-F" type
(with Schuko plug for single-phase versions only)

Standard length 10 metres

12 FLOAT SWITCH
(only for single-phase versions)

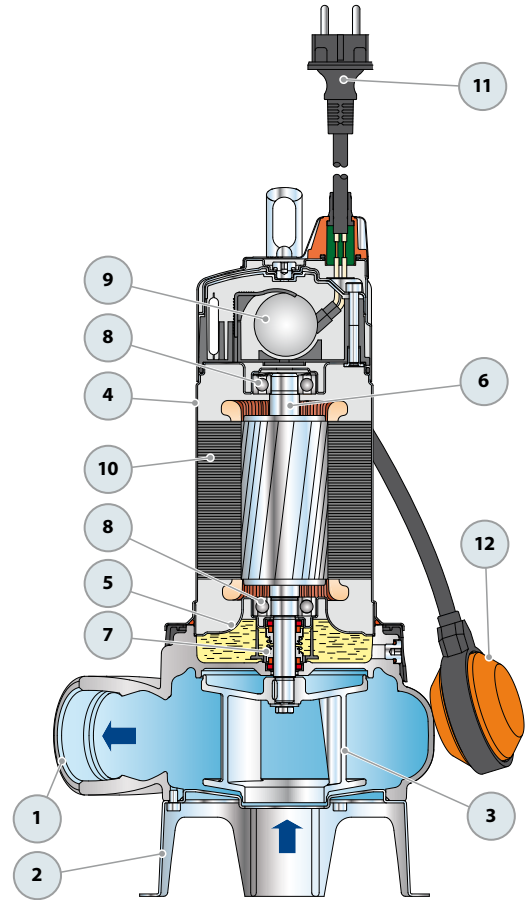

DIMENSIONS AND WEIGHT

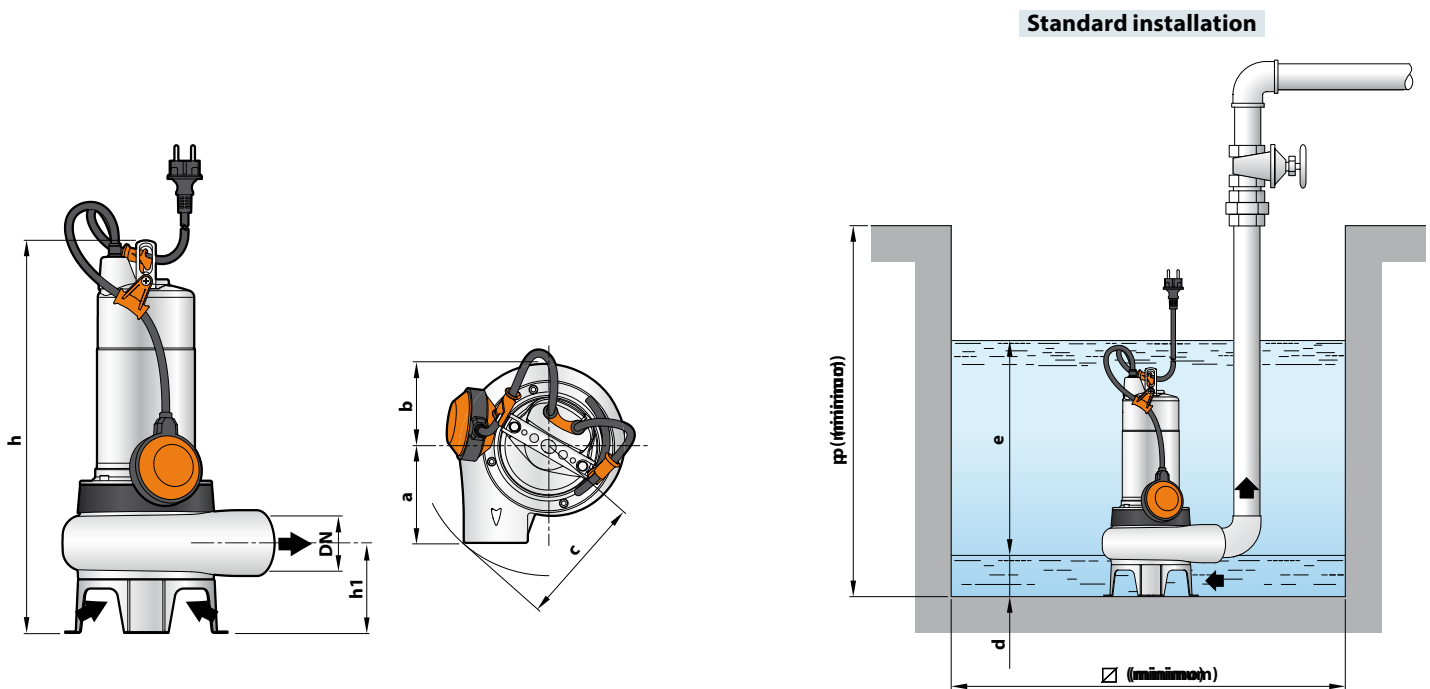

MODEL		PORT DN	Passage of solids	DIMENSIONS mm									kg	
Single-phase	Three-phase			a	b	c	h	h1	d	e	p	∅	1~	3~
BCm 10/50-MF	BC 10/50-MF	2"	Ø 50 mm	112	98	150	431	102	60	variable	500	500	14.9	13.8
BCm 15/50-MF	BC 15/50-MF						446							

ABSORPTION

MODEL	VOLTAGE		
	230 V	240 V	110 V
BCm 10/50-MF	5.0 A	4.8 A	10.0 A
BCm 15/50-MF	8.2 A	7.9 A	-

MODEL	VOLTAGE			
	230 V	400 V	240 V	415 V
BC 10/50-MF	3.7 A	2.1 A	3.5 A	2.0 A
BC 15/50-MF	5.6 A	3.2 A	5.4 A	3.1 A

PALLETIZATION

MODEL		GROUPAGE n. pumps	CONTAINER n. pumps
Single-phase	Three-phase		
BCm 10/50-MF	BC 10/50-MF	54	72
BCm 15/50-MF	BC 15/50-MF	54	72

BASE PEDESTAL KIT VX-MF – BC-MF

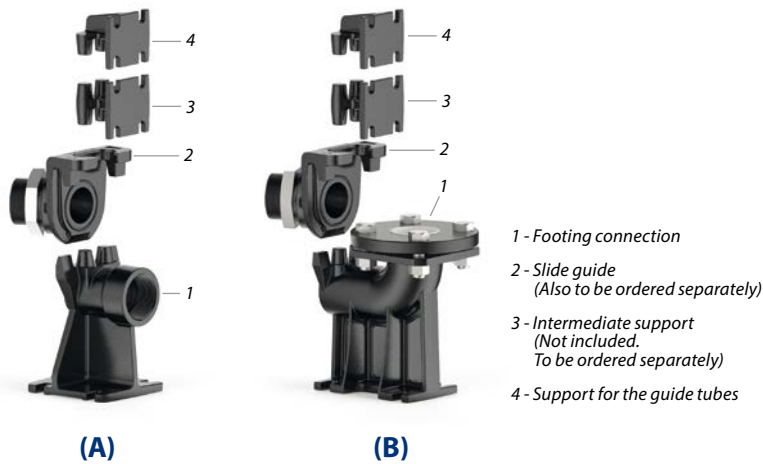

A) HORIZONTAL DELIVERY VERSION WITH 3/4" GUIDE TUBES

For VX /35-MF	Cod. ASSPVX35ST	DN 2"
For VX /50-MF , BC /50-MF	Cod. ASSPVX50ST	DN 2"

Kit consisting of:

- footing connection
- slide guide with ring nut and seal
- support for the guide tubes

B) VERTICAL DELIVERY VERSION WITH 3/4" GUIDE TUBES

For VX /35-MF	Cod. ASSPVX35STV	DN 2 1/2"
For VX /50-MF, BC /50-MF	Cod. ASSPVX50STV	DN 2 1/2"

Kit consisting of:

- footing connection complete with counterflange
- slide guide with ring nut and seal
- support for the guide tubes

SLIDE GUIDE (Also to be ordered separately)

For VX /35-MF	Cod. ASSFL005
For VX /50-MF , BC /50-MF	Cod. ASSFL005

Complete with ring nut and seal

INTERMEDIATE SUPPORT (To be ordered separately)

For guide tubes \varnothing 3/4"	Cod. 859SV340INTFA
------------------------------------	--------------------

GUIDE TUBES (AISI 304 stainless steel)

Guide tube \varnothing 3/4"	Cod. 54SARTG005
-------------------------------	-----------------

In order to ensure stability, insert the intermediate support every 2 metres

Maximum length of the tube plank: 6 metres

STANDARD INSTALLATION

1. Pump
2. Footing connection
3. Guide tubes
4. Support for the guide tubes
5. Lifting chain
6. Control box
7. Alarm float switch
8. Starting float switch
9. Stop float switch
10. Non-return valve

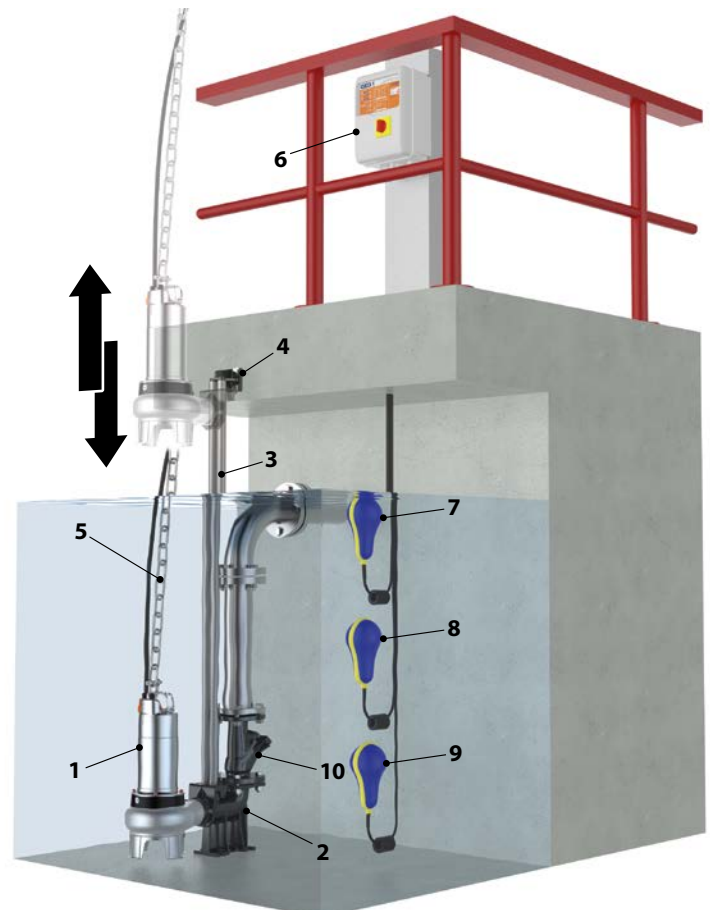

DIMENSIONS (Horizontal delivery version)

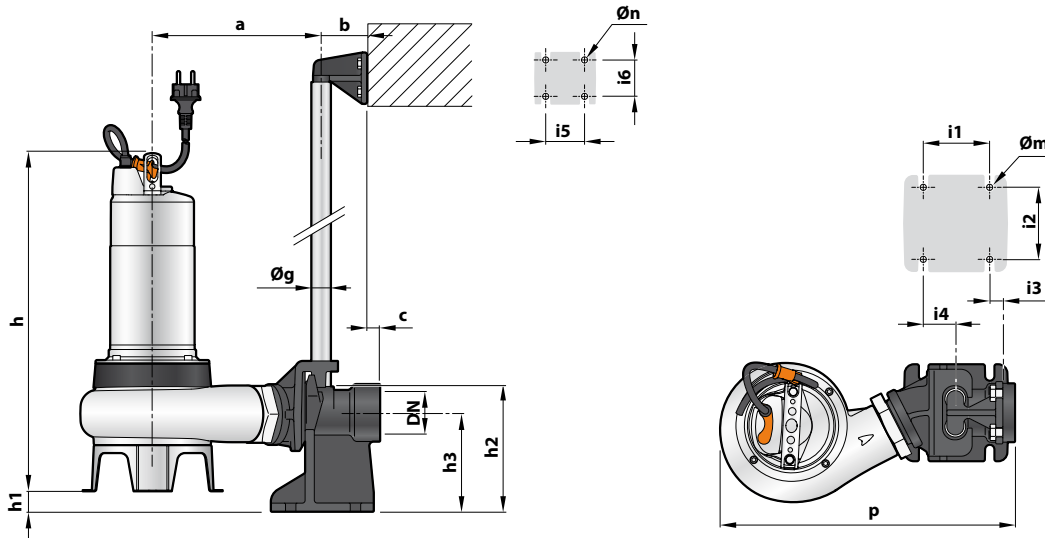

MODEL		Passage of solids mm	PORT DN	DIMENSIONS mm																
Single-phase	Three-phase			a	b	c	p	h	h1	h2	h3	i1	i2	i3	i4	i5	i6	Øg	Øm	Øn
VXm 8/35 -MF	VX 8/35 -MF	40	2"	217	61	17	387	406	45	165	130	85	94	16	40	50	48	¾"	12	11
VXm 10/35 -MF	VX 10/35 -MF							421												
VXm 15/35 -MF	VX 15/35 -MF							430												
VXm 8/50 -MF	VX 8/50 -MF	50	2"	217	61	17	390	445	29	164	215	120	72	62	50	48	¾"	14	11	18
VXm 10/50 -MF	VX 10/50 -MF							430												
VXm 15/50 -MF	VX 15/50 -MF							445												
BCm 10/50 -MF	BC 10/50 -MF	50	2"	217	61	17	390	430	29	164	215	120	72	62	50	48	¾"	14	11	18
BCm 15/50 -MF	BC 15/50 -MF							445												

DIMENSIONS (Vertical delivery version)

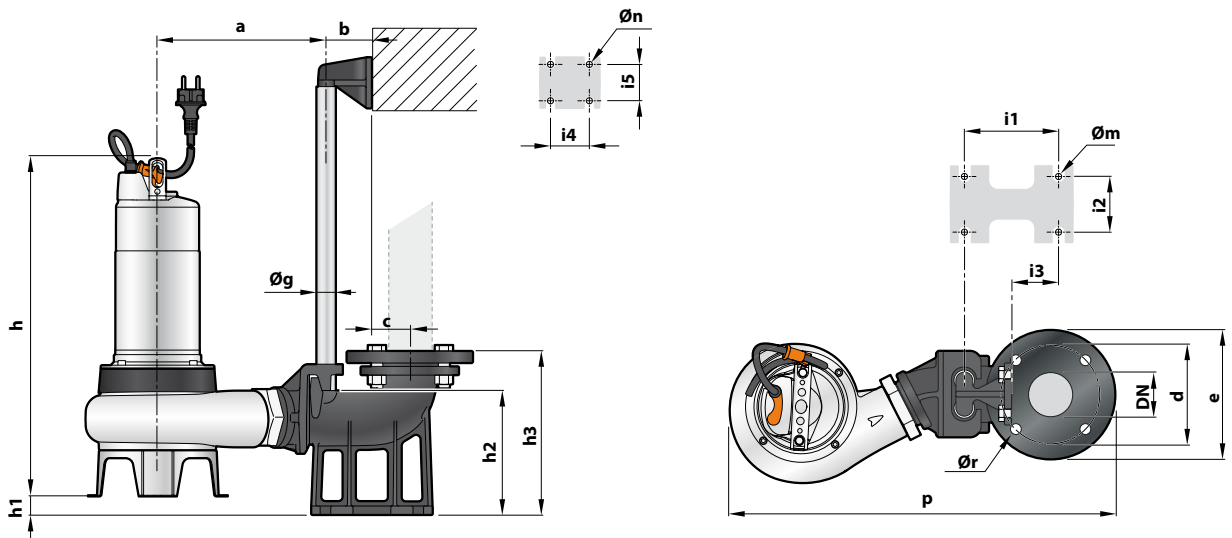

MODEL		Passage of solids mm	PORT DN	DIMENSIONS mm																		
Single-phase	Three-phase			a	b	c	d	e	p	h	h1	h2	h3	i1	i2	i3	i4	i5	Øg	Øm	Øn	Ør
VXm 8/35 -MF	VX 8/35 -MF	40	2½"	217	61	52	125	165	504	406	42	164	215	120	72	62	50	48	¾"	14	11	18
VXm 10/35 -MF	VX 10/35 -MF									421												
VXm 15/35 -MF	VX 15/35 -MF									430												
VXm 8/50 -MF	VX 8/50 -MF	50	2½"	217	61	52	125	165	507	445	26	164	215	120	72	62	50	48	¾"	14	11	18
VXm 10/50 -MF	VX 10/50 -MF									430												
VXm 15/50 -MF	VX 15/50 -MF									445												
BCm 10/50 -MF	BC 10/50 -MF	50	2½"	217	61	52	125	165	507	430	26	164	215	120	72	62	50	48	¾"	14	11	18
BCm 15/50 -MF	BC 15/50 -MF									445												