

# 3SR

## 3" submersible pumps

-  Clean water  
(Maximum sand content 150 g/m<sup>3</sup>)
-  Domestic use
-  Civil use



### PERFORMANCE RANGE

- Flow rate up to **45 l/min** (2.7 m<sup>3</sup>/h)
- Head up to **133 m**

### APPLICATION LIMITS

- Maximum liquid temperature **+35 °C**
- Maximum sand content **150 g/m<sup>3</sup>**
- Maximum immersion depth of **60 m** with a sufficiently long power cable
- Starts/hour: **20** at regular intervals
- Minimum flow rate for motor cooling **8 cm/s**
- Continuous service **S1**

### ELECTRIC MOTOR

- Oil filled **rewindable** motors (non-toxic oil for use with food) a 2 pole, 50 Hz (n ~ 2900 min<sup>-1</sup>)
- Voltage:
  - single-phase **230 V**
  - three-phase **400 V**
- Insulation: class F
- Protection: IP 68
- Shaft and jacket: **AISI 304** stainless steel
- Dimensions of the flange connection in compliance with **NEMA** standards
- **1.5 m** long power cable

### CONSTRUCTION AND SAFETY STANDARDS

EN 60335-1  
IEC 60335-1  
CEI 61-150

EN 60034-1  
IEC 60034-1  
CEI 2-3



### CERTIFICATIONS

Company with management system certified DNV  
ISO 9001: QUALITÀ



### INSTALLATION AND USE

Suitable for use with clean water with a sand content of no more than **150 g/m<sup>3</sup>**. Because of their high efficiency and reliability, they are suitable for use in domestic, civil and industrial applications such as for the distribution of water in combination with pressure tanks, for irrigation, for washing plants and for pressure boosting in fire-fighting sets, etc.

### CHARACTERISTIC CURVES AND PERFORMANCE DATA

50 Hz n= 2900 min<sup>-1</sup>

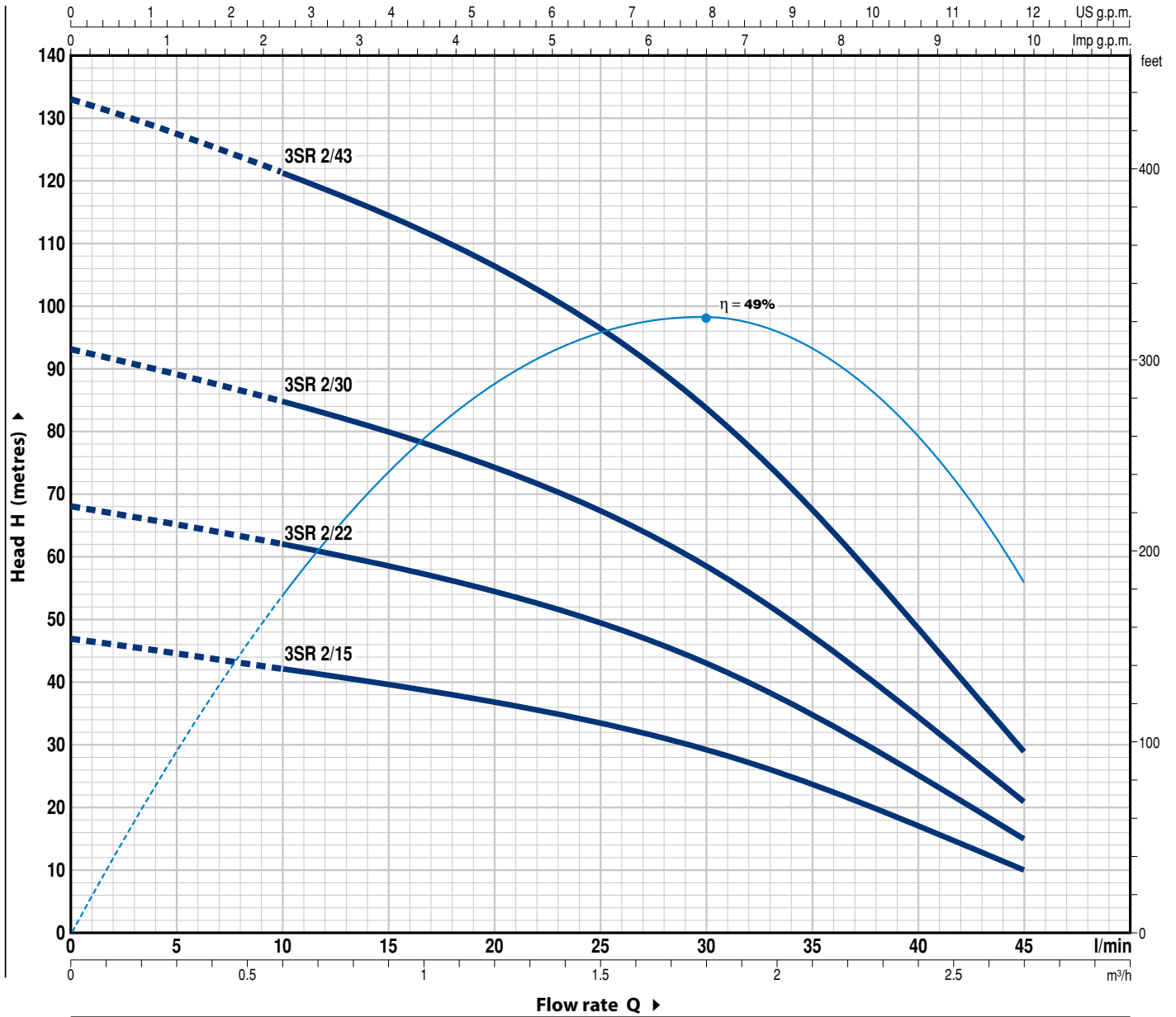

MODEL		POWER (P <sub>2</sub> )		Q	Flow rate (l/min)									
Single-phase	Three-phase	kW	HP		0	10	15	20	25	30	35	40	45	
3SRm 2/15	3SR 2/15	0.37	0.50	H metri	46.5	42	40	37	33.5	29.5	23.5	17	10	
3SRm 2/22	3SR 2/22	0.55	0.75		68	62	58.5	54.5	49.5	43	34.5	25	15	
3SRm 2/30	3SR 2/30	0.75	1		93	84.5	80	74.5	67.5	58.5	47	34	20.5	
3SRm 2/43	3SR 2/43	1.1	1.5		133	121	115	106	97	84	67.5	49	29	

Q = Flow rate H = Total manometric head

Tolerance of characteristic curves in compliance with EN ISO 9906 Grade 3B.

POS. COMPONENT	CONSTRUCTION CHARACTERISTICS
1 DELIVERY BODY	Precision cast stainless steel AISI 304 complete with threaded delivery port in compliance with ISO 228/1
2 NON-RETURN VALVE	Technopolymer
3 MOTOR BRACKET	Stainless steel AISI 304, compliance with NEMA standards
4 IMPELLERS	Technopolymer
5 DIFFUSER	Technopolymer
6 DIFFUSER PLATE	Technopolymer
7 PUMP SHAFT	Stainless steel AISI 431
8 PUMP BEARINGS	NBR rubber - Stainless steel AISI 304
9 DRIVE COUPLING	Stainless steel AISI 304
10 FILTER	Stainless steel AISI 304
11 CABLE COVER	Stainless steel AISI 304
12 MOTOR 3"	<ul style="list-style-type: none"> <li>- Oil filled rewindable motors (non-toxic oil for use with food)</li> <li>- 2 pole, 50 Hz (n ~ 2900 min-1)</li> <li>- Voltage:                             <ul style="list-style-type: none"> <li>single-phase 230 V</li> <li>three-phase 400 V</li> </ul> </li> <li>- Insulation: class F</li> <li>- Protection: IP 68</li> <li>- Shaft and jacket: AISI 304 stainless steel</li> <li>- Dimensions of the flange connection in compliance with NEMA standards</li> <li>- 1.5 m long power cable</li> </ul>

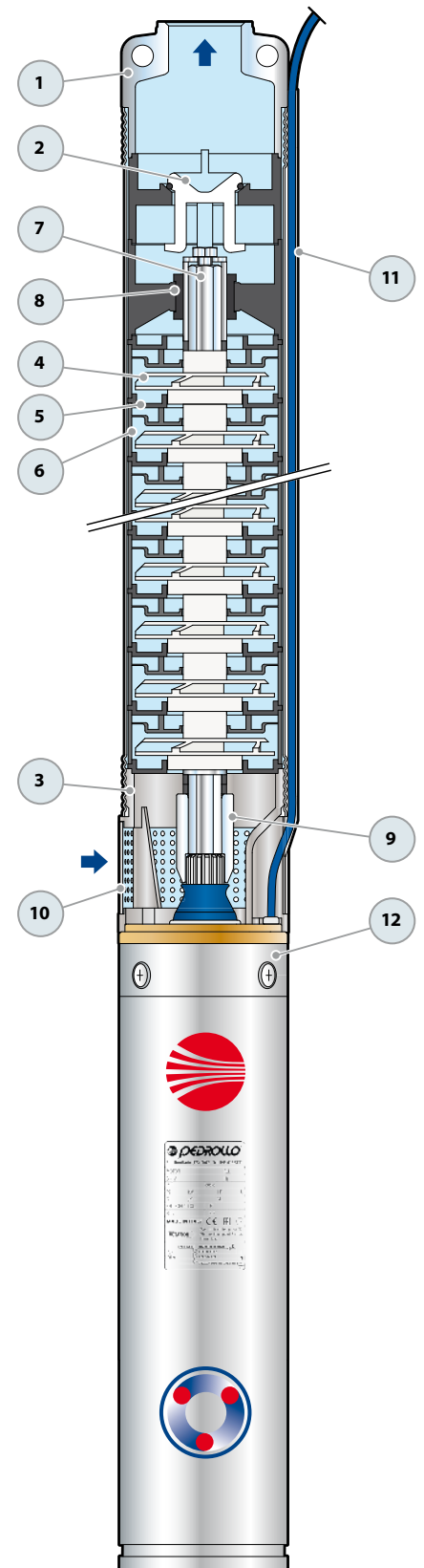

## DIMENSIONS AND WEIGHT

MODEL		PORT DN	Ø	DIMENSIONS mm						kg	
Single-phase	Three-phase			h1	h2		h		1~	3~	
3SRm 2/15	3SR 2/15	1"	76	568	373	353	941	921	10.2	9.4	
3SRm 2/22	3SR 2/22			738	393	373	1131	1111	11.4	10.8	
3SRm 2/30	3SR 2/30			934	433	393	1367	1327	13.6	12.8	
3SRm 2/43	3SR 2/43			1250	475	433	1725	1683	15.2	14.6	

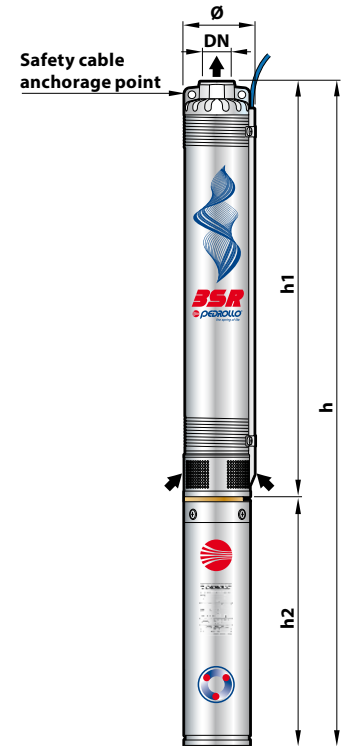

## ABSORPTION

### Single-phase versions

MODEL	Rated power P <sub>2</sub>		Axial load N	Capacitor (VL=450V) µF	ABSORPTION
	kW	HP			
230 V / 50 Hz					
3SRm 2/15	0.37	0.50	800	12.5	3.4 A
3SRm 2/22	0.55	0.75		16	4.5 A
3SRm 2/30	0.75	1		20	6.0 A
3SRm 2/43	1.1	1.5		30	8.0 A

### Three-phase versions

MODEL	Rated power P <sub>2</sub>		Axial load N	ABSORPTION
	kW	HP		
400 V / 50 Hz				
3SR 2/15	0.37	0.50	800	1.5 A
3SR 2/22	0.55	0.75		1.9 A
3SR 2/30	0.75	1		2.6 A
3SR 2/43	1.1	1.5		3.5 A